

NXT
NEXT WELDING TOOLS

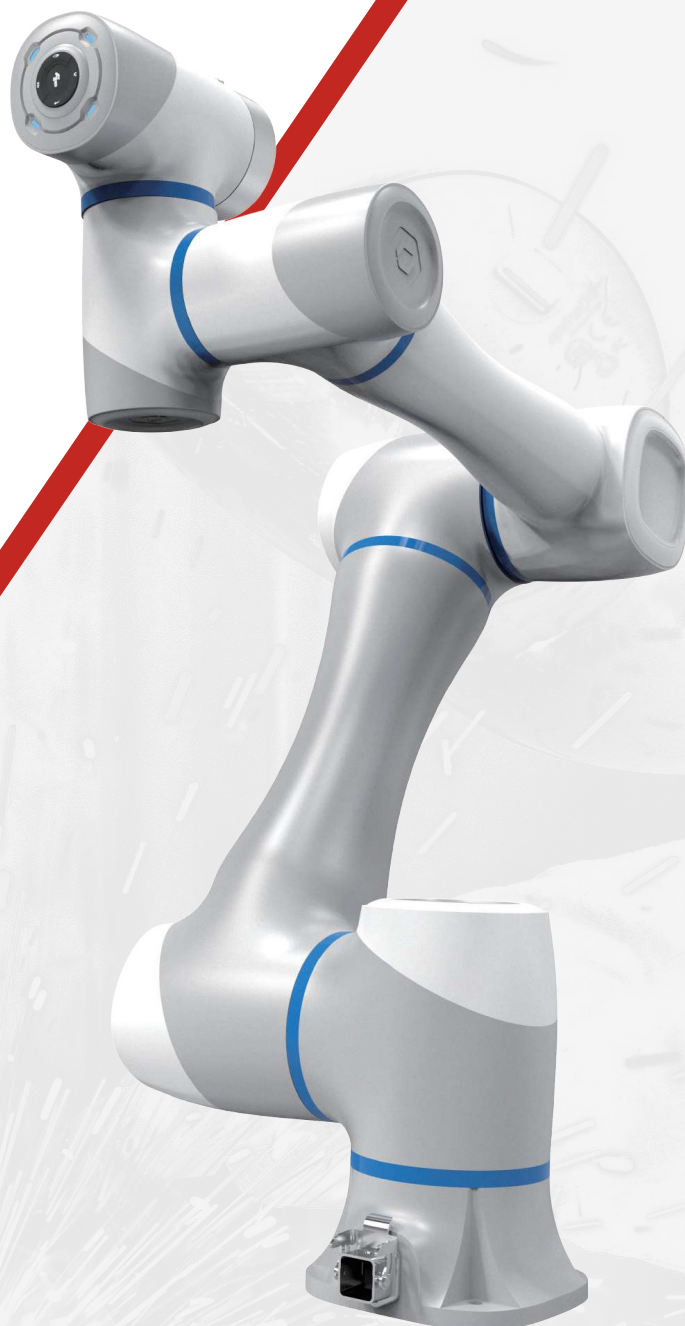

NXT COBOTS

Cobots by NXT.

- Manufacture with the top collaborative robot's technology.
- Unique algorithm for smooth approximation to the position points.
- Easy to implement with many applications like: Pick and Place, cutting, welding, polishing, screwing, Inspection, etc.
- Open interface easy to program, linkable with any PLC, computer or included pendant.
- Four different sizes with different distance and load capacity.
- Super safe technology, with immediate stop with or without touching.
- Reputability of +/- 0.03 mm.
- 3 years of warranty.
- 100% duty cycle.

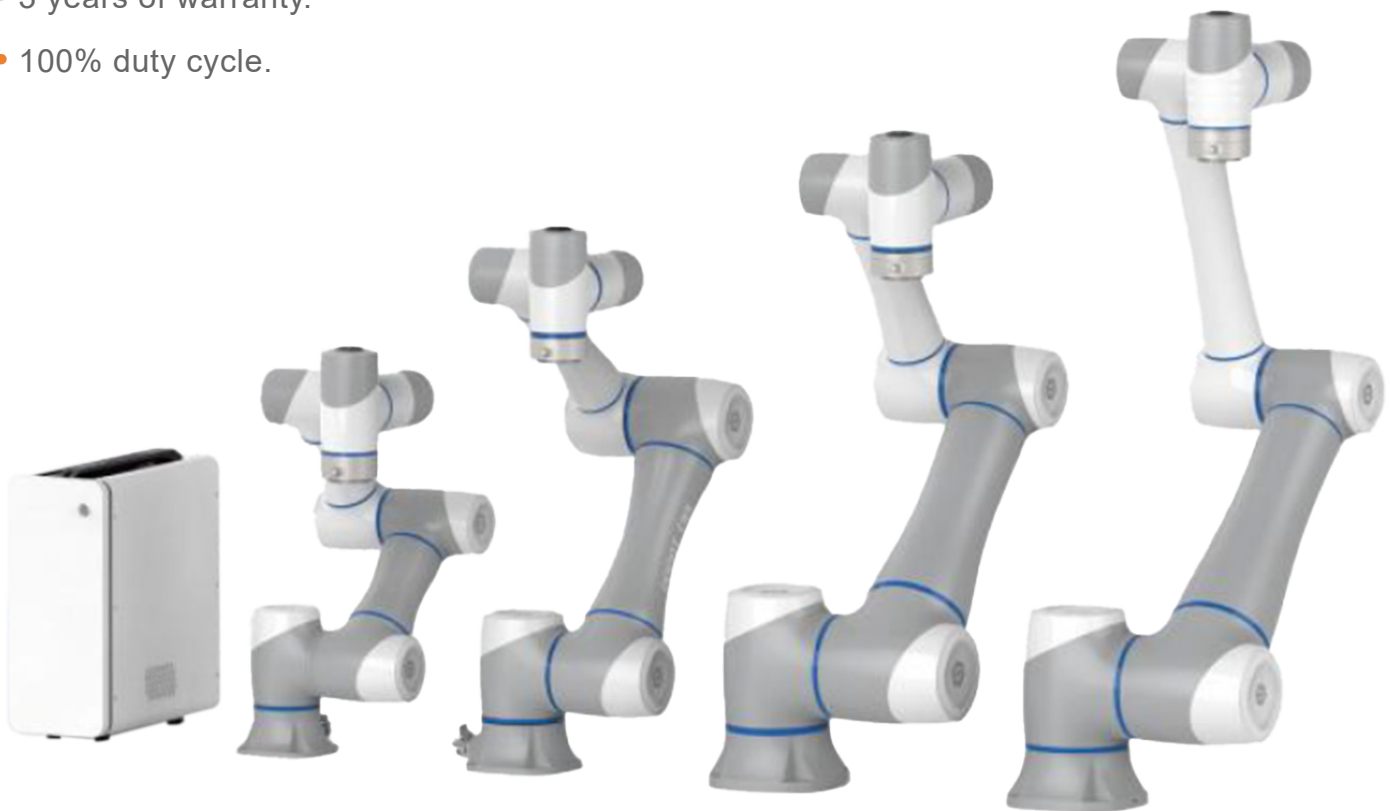

AVAILABLE MODELS

CR3 Device Specifications & Dimensions



16.5 kg 

620 mm 

± 0.02 mm 

AVAILABLE MODELS

CR5 Device Specifications & Dimensions



25 kg



900 mm



± 0.02 mm



AVAILABLE MODELS

CR10 Device Specifications & Dimensions



40 kg 

1300 mm 

± 0.03 mm 

AVAILABLE MODELS

CR16 Device Specifications & Dimensions



40 kg



1000 mm



± 0.03 mm



Pick and Place Application

All kind of accessories available.

- Mechanical gripper



- Magnetic gripper



- Pneumatic gripper



- Customized gripper



Cutting Application

PLASMA

- Automatic interface with oxyfuel and Hypertherm plasma.
- Safety interface with Powermax 65, 85 and 105, no protection of high frequency needs it.
- Easy to program shape and bevel cutting.
- Off position available to access narrow angles.
- Cutting capacity up to 1 inch of CS with bevel.



Sistema de plasma Powermax65 SYNC



Sistema de plasma Powermax85 SYNC



Sistema de plasma Powermax105 SYNC

Cutting application

OXYFUEL

- Provided by GCE.
- Automatic ignition with automatic interface with the Cobot.
- Option of programming storage available.



Welding Application

WELDING

- Our equipment can connect with any welding machine in the basic function of on and off.
- It can work with any semiautomatic welding process. TIG, Traditional MIG, Pulsed MIG, Twin wire MIG, Plasma welding, laser.
- Fully interface with NXT AMIG500PR, all parameters can be controlled with the robot interface pendant or computer.
- Program storage capability.
- Quick reference available with only 2 touches for rectangular forms and 3 touches for circular applications.



Welding Application

PACKAGE OPTIONS AVAILABLE

1. | NXT COBOT WITH NXT POWER SOURCE FULLY INTERFACE. THE PACKAGE INCLUDES:

- Cobot 10 or 16 with controller and pendant.
- NXT Welding system model AMIG500PR.
- Robotic wire feeder with 4 rolls.
- Robotic water-cooled torch of 500 amps.
- Water cooler.
- Bracket for the welding torch.
- Advance programming capability.
- Programmable welding pulse for special applications.



Welding Application

PACKAGE OPTIONS AVAILABLE

2. | NXT COBOT WITH STANDARD WELDING MACHINES (LINCOLN ELECTRIC, MILLER OR ESABAAVAILABLE). INCLUDES:

- Cobot 10 or 16 with controller and pendant.
- Available welding systems:
 - Lincoln Electric Flextec 500 with LF774.
 - Miller XMT 450 with S774S.
 - Esab Warrior 500 with Warrior feed 304.
- NXT robotic air- or water-cooled torch.
- Bracket for the welding torch.
- Simple interface just turns on and off.
- For standard applications of welding.



Welding Application

PACKAGE OPTIONS AVAILABLE

3. | NXT COBOT WITH ADVANCE WELDING MACHINES (LINCOLN ELECTRIC, MILLER OR ESAB AVAILABLE). INCLUDES:

- Cobot 10 or 16 with controller and pendant.
- Available welding systems:
 - Lincoln Electric Powerwave S500 with PF84.
 - Miller Deltaweld 500 with Intelx.
 - Esab Aristo 4000 with Aristofeed.
- NXT robotic air- or water-cooled torch.
- Bracket for the welding torch.
- Simple interface just turns on and off.
- For standard applications of welding.



Other available solutions

- TIG welding application with Lincoln Electric or Miller machines.
- Laser welding application with NXT power source.
- Tandem Mig with NXT MIG1000.

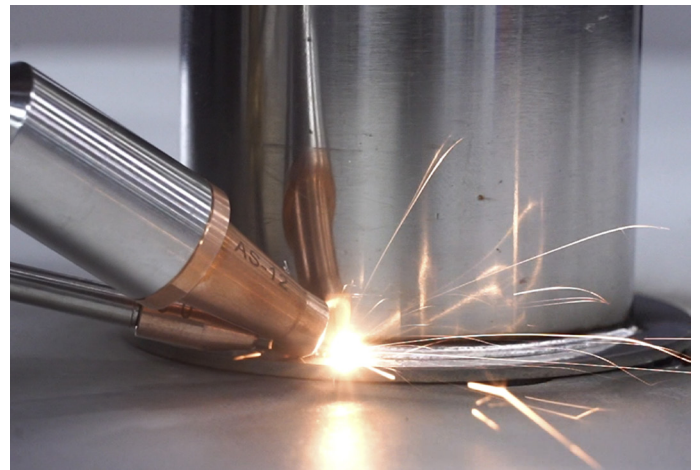
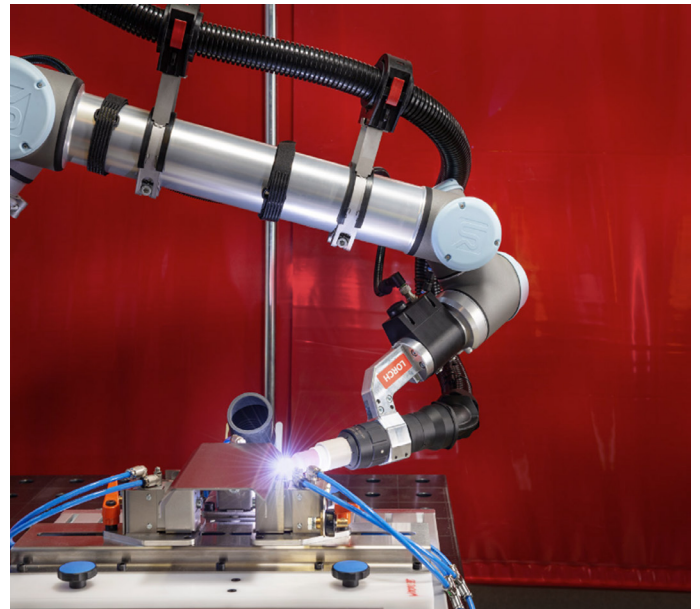

Available Accesories

1. | SUPPORTS.



Available Accesories

2. | WORKING TABLES WITH TOOLS.

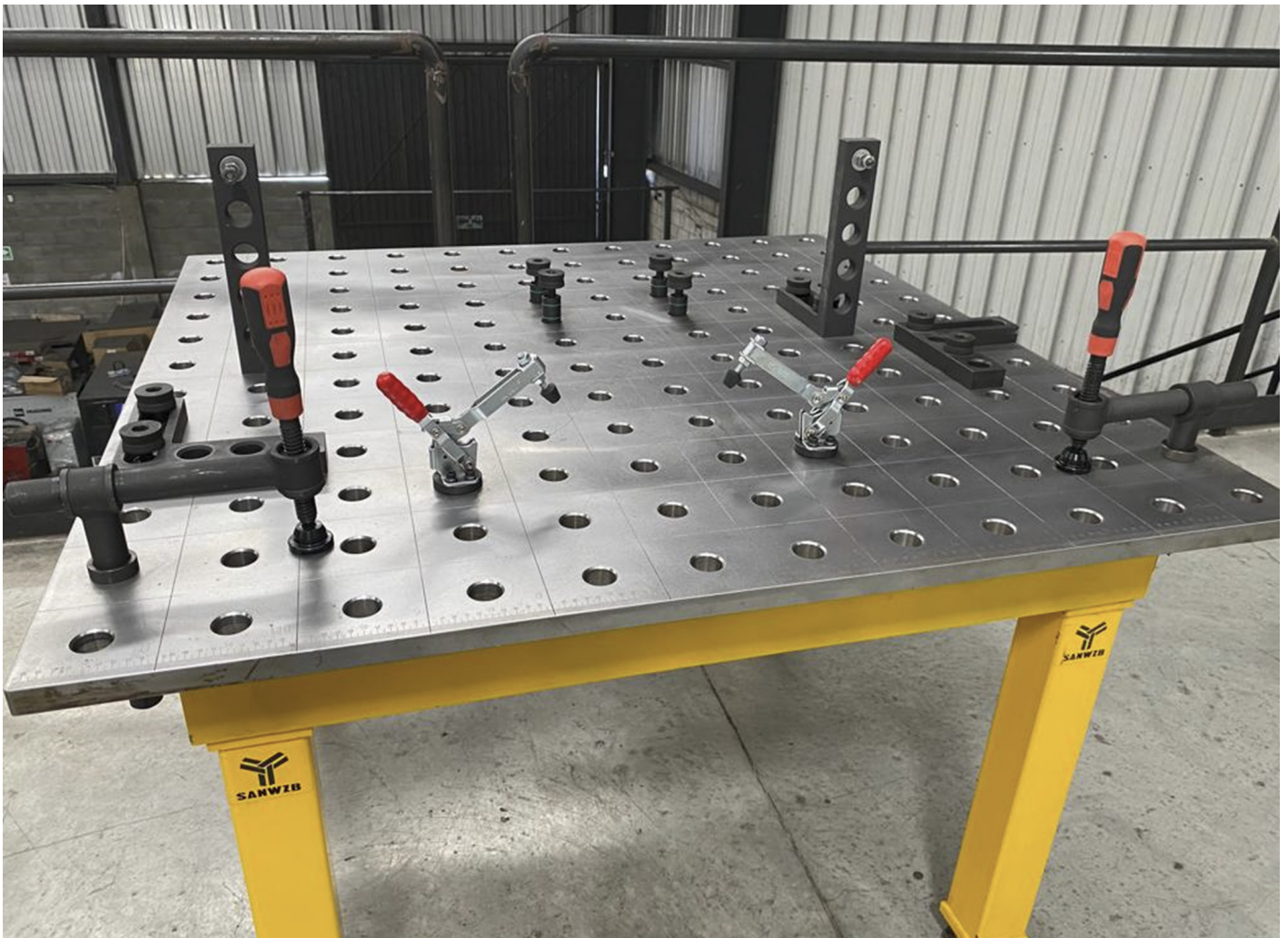

Available Accesories

3. FUME EXTRACTION SYSTEM



Available Accesories

4. | EYE PROTECTION.



Available Accessories

5. | LASER SEAM TRACKER.



Available Accesories

6. | BEAM WITH PLC CONTROLLER CAR.

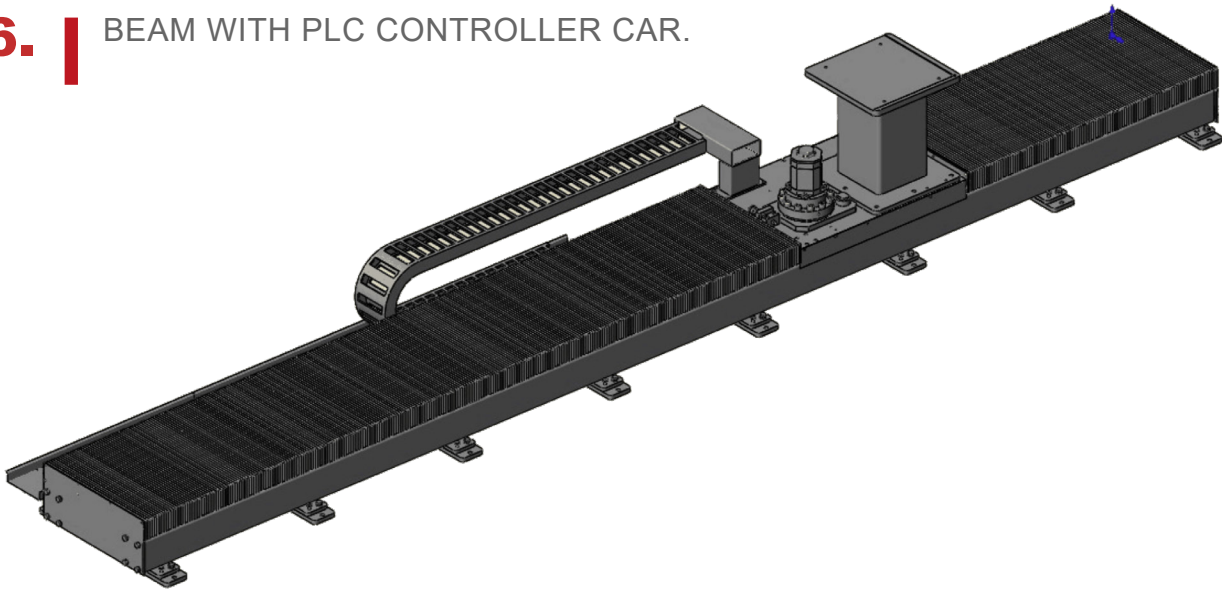

7. | ROBOTIC POSITIONER.





Calle Guam 68, Col. Euzkadi, C..P. 02660,
Del. Azcapotzalco, Ciudad de México.

TEL. 5521218632